

**DQC ST-SERIES SNAP-TITE 71  
INTERCHANGE OLD STYLE  
FEMALE COUPLER**

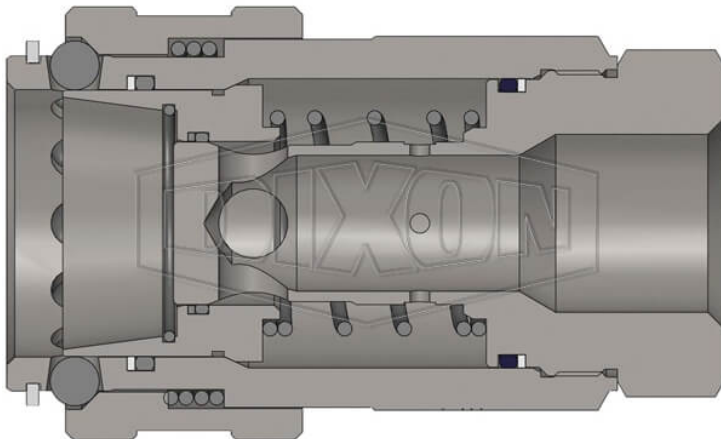

DATE  
: 07/10/2026 11:00 AM

SKU  
: 1787

BRAND  
: DIXON VALVE

MODEL  
: 16STF16-SS

**Construction:**

Machined components are manufactured using solid bar stock  
Stainless steel balls, retaining rings and springs maximize corrosion resistance and extend service life.  
Steel componentry is plated using ROHS Compliant Trivalent Chrome.  
Steel coupler sleeves are hardened to resist deformation and maximize service life.

**Available Options:**

Contact Dixon for all available option adders  
Standard seal options include: FKM, EPDM, Mil-Nitrile and Fuel Nitrile  
Kalrez® seal options include: 4079, 6375 and 7075  
Oxy-clean treatment is available

**Compatibility & Interchange Data:**

Interchangeable with Snap-Tite 71-Series

**Safety notes:**

WARNING: Cancer and Reproductive Harm- [www.P65Warnings.ca.gov](http://www.P65Warnings.ca.gov)

**TECHNICAL SPECIFICATIONS**

<b>Body Size</b>	2"
<b>Burst Pressure</b>	10000 PSI (700 bar)
<b>Factory Part Number</b>	16STF16-SS
<b>Hex</b>	3.78"
<b>Length</b>	6.20" (157.5mm)
<b>Material</b>	316 Stainless Steel

\* Referential image  
\*\* Some features may vary without prior notice. Sale subject to inventory availability

## TECHNICAL SPECIFICATIONS

<b>Maximum OD</b>	113.5mm
<b>Maximum Operating Pressure</b>	3000 PSI (200 bar)
<b>Temperature Range</b>	-40°F to +250°F (-40°C to +121°C)
<b>Thread</b>	Female NPTF
<b>Thread Size</b>	2" - 11-1/2